

auto electrical parts

Technical Information Sheet

Part No. 0-445-86

Low profile Amber LED beacon, 12-110 volt dc with polycarbonate amber lens, magnetic fixing, retractable cable and cigarette lighter plug. 45 quad flashes per minute, 6 high intensity LED's. I 130 x w 130 x h 95mm. CE approved.

Additional Information

The beacon is supplied with plastic adhesive gasket to protect vehicle surface.



Technical Drawing (not to scale)

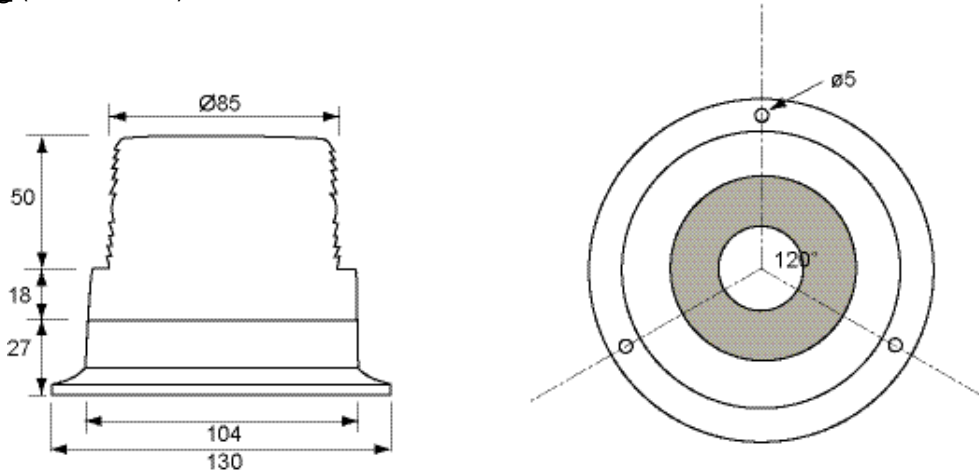

Specification

Type	High intensity LED beacon
Colour	Amber
Number of LEDs	6 x 1 watt
Voltage rating	12 - 110 volt dc
Current	0.35 amp @ 12 volt dc
Flash rate	45 quad flash per minute
Lens material	Polycarbonate
Magnet	70mm donut
Weight	670g
Dimensions	I 130 x w 130 x h 95mm
Approvals	CE
Protection	Waterproof against spray

The information contained in this document is correct to the best of our knowledge at the time of printing. However, specifications may change at any time without notice.